



**RAUMAG
JANICH**

A LEADER IN DAMPER TECHNOLOGIES



Toggle disc valves

DVGW approved

PERFECT DAMPER TECHNOLOGIES FOR INDUSTRIAL PLANTS

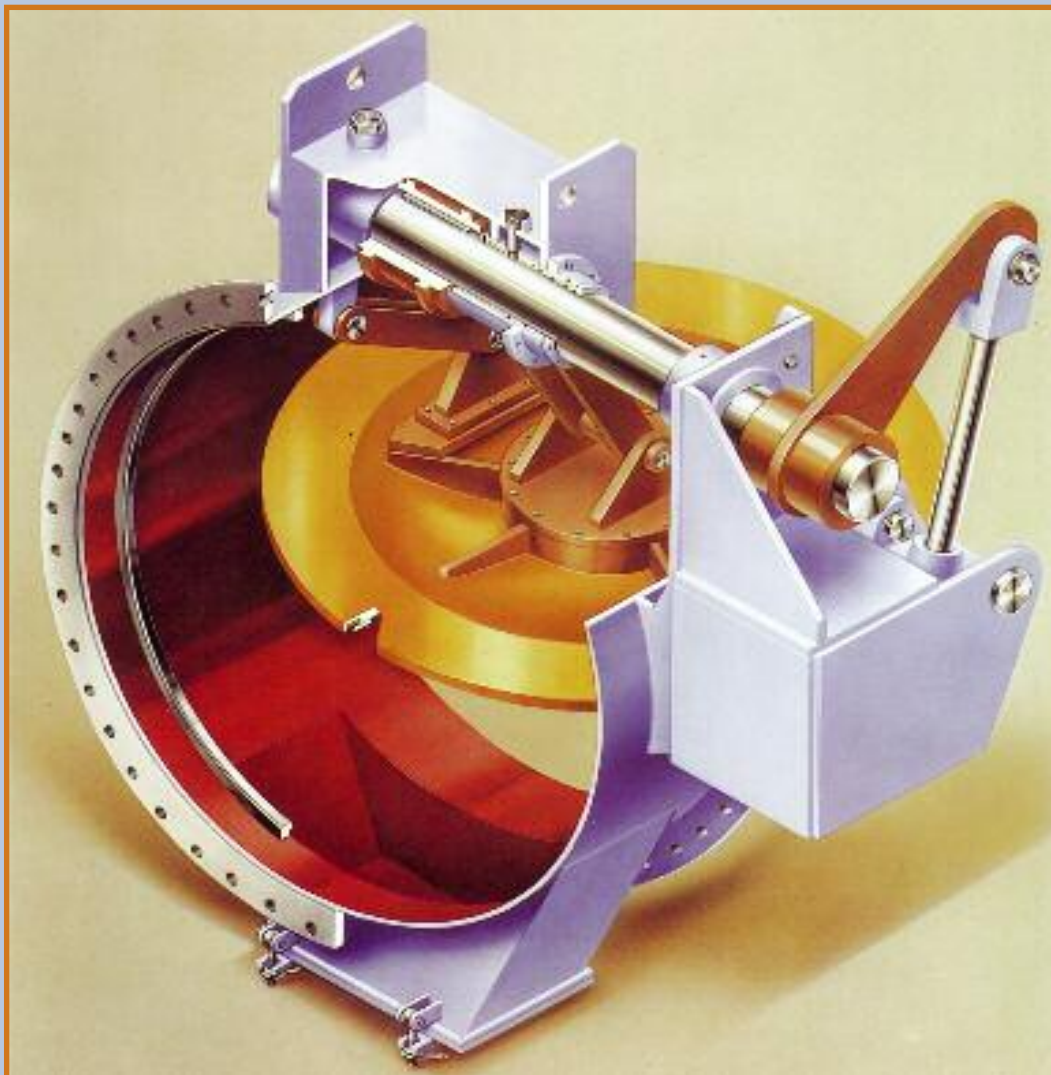

Toggle disc valves are used for the shut – off of gas mains .They are valves considered technically tight within the definition of DIN 3230.The high sealing efficiency is achieved by means of an endless sealing element upon which the valve disc is pushed down by the action of the valves main levers.

When the valve is opened the disc is initially lifted away from the seal in a coaxial direction and subsequently tilted about through the action of the toggle levers until it reaches a position parallel to the duct centreline.

Operated in this manner the seal is not subjected to frictional wear. Toggle disc valves can be powered by any type of actuator. In combination with counter weights or spring action they may serve as fast closing or opening emergency valves.

Picture below:

toggle disc valve, ND 3000mm dia., designed as emergency valve, DVGW approved.

Supplied to ALSTOM POWER BOILER Stuttgart, for a blast furnace gas fired boiler at Mittelsbühren power station. The valve is opened hydraulically while closing is effected by means of two counterweights totally independent of external energy in compliance with prevailing safety regulations.

Toggle disc valves are supplied to nominal diameters ranging from 200 to 4000 mm. Dependent upon the type of seal, bearing arrangement and choice of construction materials, they may be used at elevated temperatures of up to 700 degrees C . Flanges are made to suit any of the applicable standard specifications.

The valves preferential way of fitting into the duct should be such that the pressure of the gas enhances the forces generated by the actuator and levers in holding the disc tightly closed .In case a different fitting position is envisaged this fact should be known at the design stage. Moreover, the fitting should provide for a horizontal position of the valve drive shaft. A vertical drive shaft position is of course possible, but requires modifications to the drive levers, and, for larger valve sizes, an additional thrust bearing.

High differential pressures can be accommodated if valve casing and disc are accordingly dimensioned. However, considering the opening torque and sizing of valve shaft and levers, a differential pressure of 100 – 500 mbar, depending on the valve diameter, should not be exceeded.

To avoid the build up of dust on and in the vicinity of the sealing surface the casing can be equipped with a dust collecting hopper.

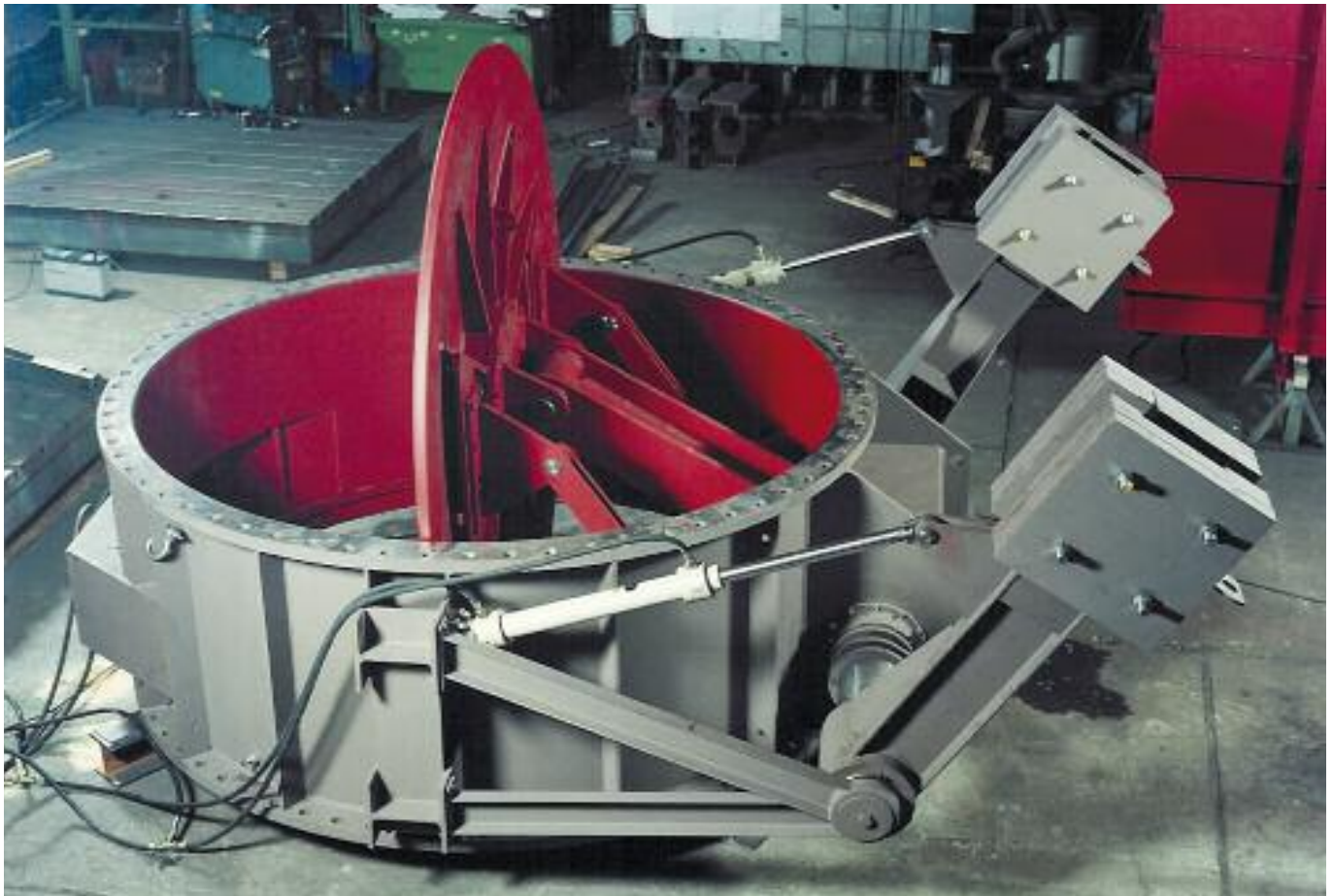

Toggle disc valves

DVGW approved

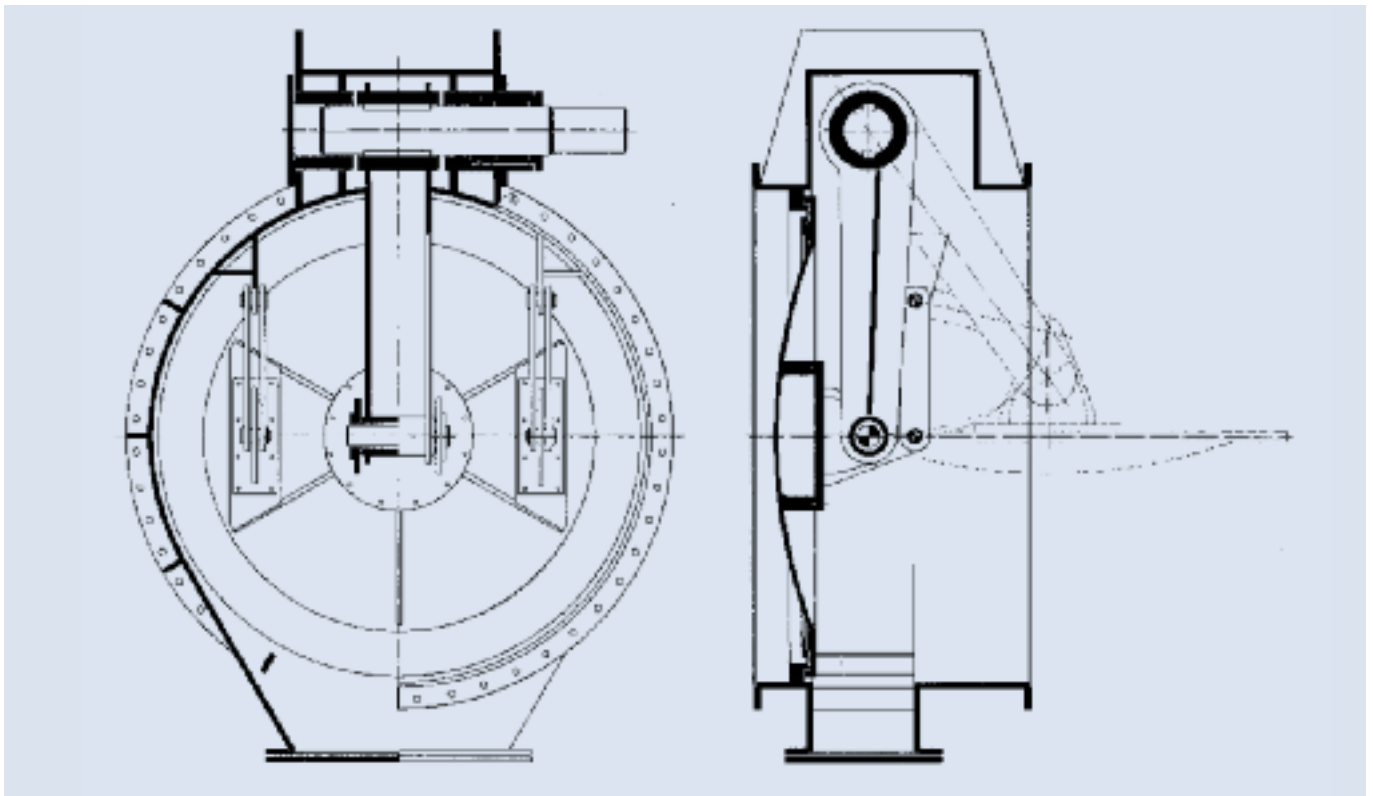

Sealing alternatives.

Dependent upon service conditions and valve application the following seal variations are being used:

Sketch 1

Stainless steel seal landing bar as integral part of the casing in combination with an endless elastic seal fitted to the valve disc. The clamping ring facilitates the replacement of the seal as well as providing its secure attachment. Several seal materials are available and are selected to suit service conditions.

Sketch 2

Stainless steel landing bar as integral part of the casing and a metallic seal fitted to the disc. This type is used for very high temperatures and / or abrasive mediums. Several material combinations are utilized.

Sketch 3

Seals as described in combination with a rinsing device. Liquids or gas may be used for cleaning.

Sketch 4

Seals generally as described, however, design as double seal with venting or seal gas injection facility. Used, for instance, for burner emergency valves.

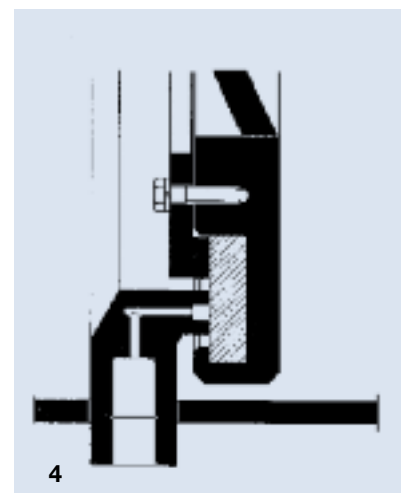
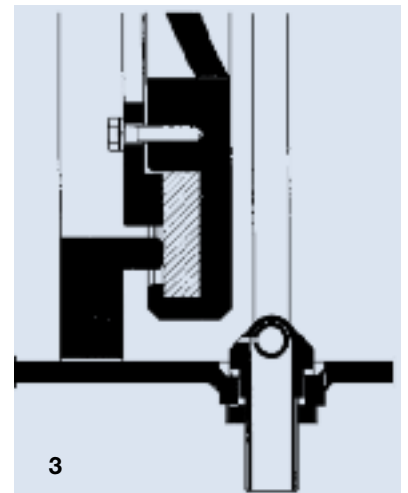
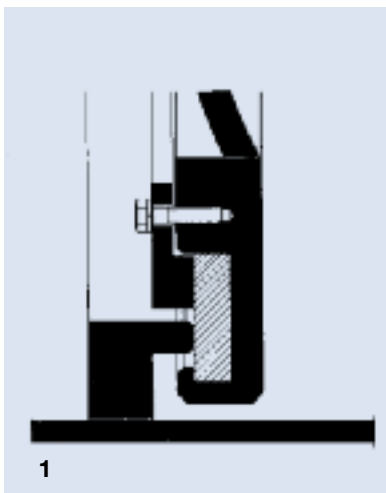

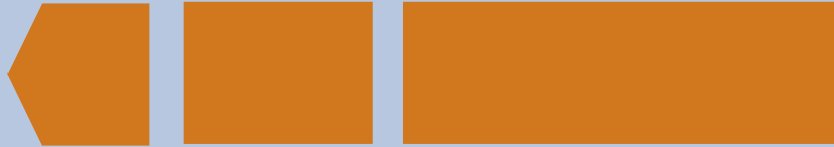

Arrangement of drive shaft

Picture above:

Sleeve bearings, if required also maintenance free. Shaft seal fitted in a replaceable cartridge, if required with a nitrogen seal gas injection connection.

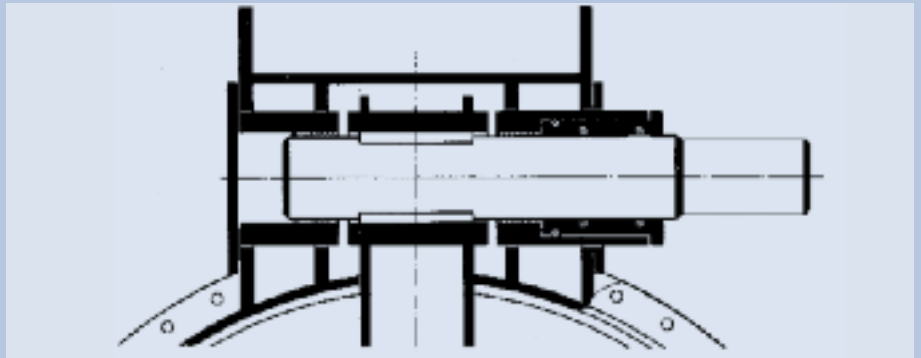

Centre picture:

External spherical sleeve bearings fitted into totally enclosed dust tight housings. Shaft seal by means of gland packing or O-rings, if required with nitrogen seal gas connection.

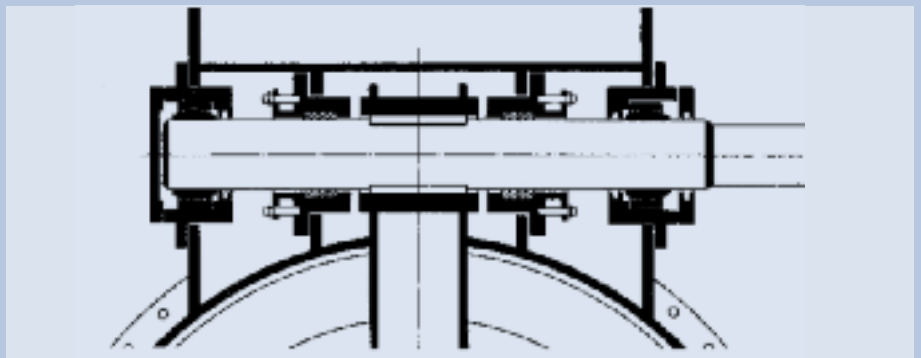

Picture below:

Toggle disc valve, designed as burner safety valve, ND 1300 mm dia. Emergency closing within 0,5 sec. Equipped with double seated landing bar and nitrogen seal gas injection facility.



RAUMAG-JANICH – Perfect technique, Quality and Security

RAUMAG JANICH-Systemtechnik GmbH
Im Grund 6
96528 Rauenstein/Thüringen
Telefon: 0049 36766 881-0
Fax: 0049 36766 81032
Mail: info@raumag-janich.de
Web: www.raumag-janich.de



RAUMAG JANICH-Systemtechnik GmbH
Zweigniederlassung Beckum
Kirchstrasse 9
59269 Beckum
Telefon: 0049 2525 4141
Fax: 0049 2525 6332
Mail: info@raumag-janich.de