



Hot gas Guillotine damper for one of the world largest Limestone milling plants

RAUMAG-JANICH Sytemtechnik GmbH supplied hot gas Guillotine dampers for one of the world largest limestone drying and milling installations at the Hoping Cement plant in Taiwan. Specifically developed and designed by RAUMAG-JANICH for service in large installations this type of Guillotine is suitable for handling and isolating heavily dust laden, hot flue gas. The new development was based upon a design originated by JANICH Spezial-armaturen, Beckum in 1971, which has since seen successful service in more than 500 different applications, worldwide. The Guillotines for the Hoping plant facilitate the bypass operation, thus permitting maintenance of the milling plants without interrupting the kiln plant, as well as providing safety for the maintenance crew.

The supply consisted of two Guillotines each with the dimensions 3200 x 4600, 4200 x 3300 and 4000 x 4200 mm.

The operating and design temperatures are 360°C and 400°C respectively. Design pressure is 110 mbar and the max. dust load is 1100 g/cbm.

The Guillotine blade is synchronously driven by two rack and pinion drives positioned on each side of the damper. This prevents any misalignment or jamming of the blade. The blade design can accommodate heat expansion with little distortion. Whatever distortion there is, will be compensated by the highly resilient stainless steel loop seals.

Three of a total of six Guillotines during final assembly and testing in the works of RAUMAG-JANICH.





Guillotine damper NW 4000 x 4200 mm for the Cement plant Hoping (Taiwan).

For smaller Guillotines the sealing system **NICROFLEX® MLO** (sketch 3) is recommended. This sealing method has been introduced in 1971 for the handling of dust laden gases in Powerstations and Cement plants. The sealing elements consist of oblong, resilient, stainless steel loops, able to regain their original shape after long periods of deformation during which the damper is closed. Dust deposits and crustations simply break away due to loop flexing. Even when deformed by point loads (tramp material) the seals regain contact with their mating surfaces within a short distance. A very high sealing efficiency is thereby achieved.

For Guillotines with large nominal dimensions the sealing system **NICROFLEX®-HIPERFORM** (DBPa) is preferred because of its even greater flexibility. Geometrically shaped as a fully circular metal loop, this sealing element affords a permanently high resilience of more than 30 mm.

In relaxed condition (damper open) the Vee-shaped backup bar positioned inside the circular loop provides additional lateral support (sketch 1) which protects the loop against damage or destruction from vibrations emanating from high gas velocities and turbulence.

In stressed condition, (damper closed) a wide area of contact is created between seal and mating surface providing an excellent sealing effect (sketch 2). The parts of the loops protruding sideways retain their curved pressure shape and are thus able to withstand high pressure levels.

With double seal and seal air, a 100% gas tight, man safe isolation can be achieved at over-pressure conditions.

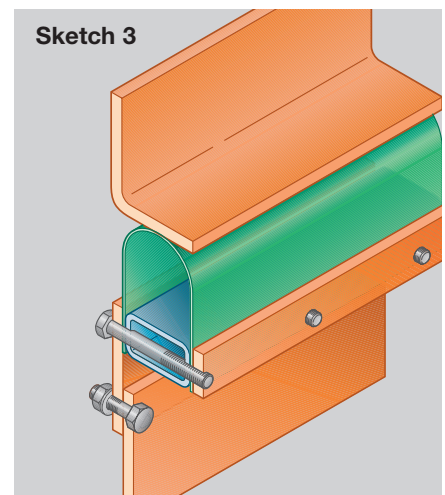
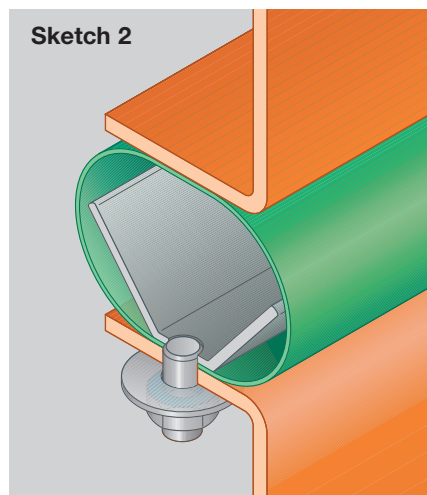
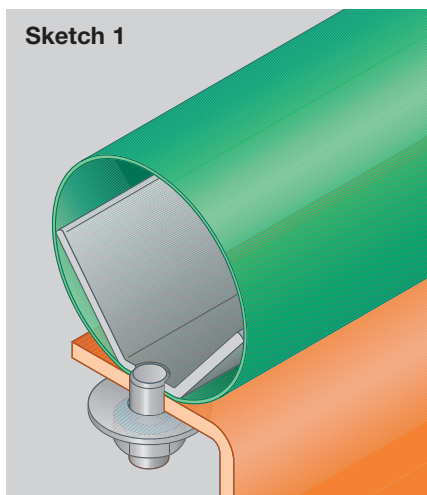

RAUMAG-JANICH – perfect Technique, Quality and Security